

Telecommunications



vadatech
THE POWER OF VISION

About us

VadaTech is a world leader in the design and manufacture of embedded computing solutions. The products include configurable application-ready systems and their building blocks of boards, chassis and enabling software.

Global operation: Headquarters, design and manufacturing facilities in Henderson, NV, USA with design, support and sales offices in 4 countries in Europe and Asia Pacific. Our collaborative approach to product development enables us to share 'the power of vision' with our customers.

Our Philosophy: At VadaTech, we differentiate ourselves from other embedded computer manufacturing companies by incorporating our customers' vision into the product specification and development process; all the way through to deployment. Our partnership philosophy with our customers expands their engineering resources, increasing their value and reducing their time to market.

Choose VadaTech:

- We manufacture in-house in USA
- We are technology leaders
- We comit to our customers
- We deliver complexity



vadatech
THE POWER OF VISION

Quality Assurance

- Vadatech has an in house IPC 610 CIT, IPC 620 CIT and J-STD-001F CIT which provides those employees dealing with electronics manufacturing, soldering operations, wire harness assembly, and cable assembly the expertise that ensures Vadatech can exceed customer expectations and requirements.
- VadaTech is AS9100 certified
- VadaTech is RoHS compliant
- "The Management team of VadaTech and all its employees are committed to providing superior, cost effective quality products and services to our customers. We shall achive this by establishing an effective Quality Management System through continual improvements of our process, products, services and complying with our customer's regulatory requirements."



Highly specialized design capability

VadaTech recognizes that Telecom integrators are looking for solutions that meet their specific requirements, and that such solutions are not always achievable using existing modular products, especially in deployment and production phase.

We take time to assess your requirements fully, and will often propose solutions that require some degree of customization in hardware or software. This allows us to provide highly-specialized solutions or to offer significant cost savings through hardware/software optimization.

At a simpler level, we can customize the appearance of most products for production orders.

VadaTech robust process is in place for revision-locking to maintain consistency of supply.

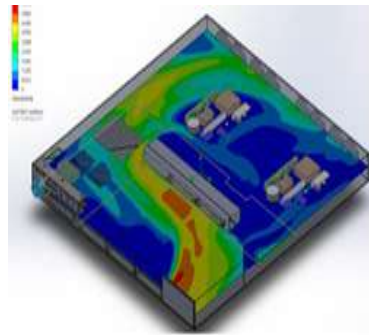
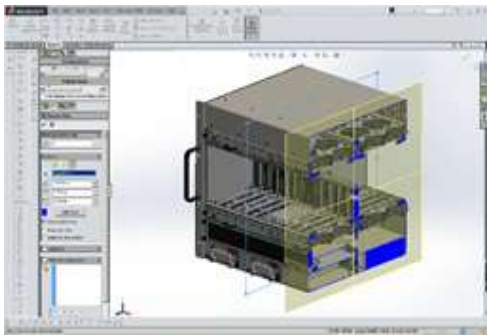

VadaTech support special design requirements and services(*) including:

- In-house design and layout
- Modelling (FloTHERM or similar)
- Testing (climatic chamber, vibration table)
- Custom overlay
- DAQ synchronization, characterization and calibration
- Certified test record
- Integrated platform user manual
- Standard support package
- Training and integration

(*)Conditions apply

Manufacturing

An AS9100 certified company, VadaTech has a 70,000 square foot manufacturing facility located in Las Vegas, Nevada. It is equipped with the latest state-of-the-art equipment ensuring the highest quality and consistency. This equipment includes several full SMT lines and automated optical inspection. The company also has in-house conformal coating, x-ray inspection, thermal/humidity chamber, shaker table, BGA removal, RTV/epoxy dispenser, stencil cleaner, and selective solder machine.

Every product lot on the SMT line goes through first article inspection. VadaTech is able to trace every serial number to a specific lot and operator at the time of production. With the most advanced equipment and stringent quality processes, we are able to produce highly complex boards/systems with high precision, traceability, and reliability.

Operating our own manufacturing facility, closely coupled with our design engineers, enables us to meet development and deployment schedules without compromise. You can have confidence in the quality and reliability that underpins our warranty.

Partners



Application areas

- Call Servers/Gateway Controllers/VoIP-Server
- Cloud Radio Access Network (CRAN)
- HLR/HSS, IMS (x-CSCF, MRF)
- Media Gateway/Trunking GW
- Application and Media Server & Proxies
- Packet core – SGSN, GGSN
- Signaling Gateway
- Radio Network Controller (RNC)
- WiMAX Access Controller (WAC)
- Base Station (BTS, Node B; WiMAX)
- Video / IPTV - transcoding/storage
- LTE smallcell gateway HeNB GateWay, 3GPP IPsec Gateway SeGW
- Mobile Switching Center
- Passive Optical Network

Introduction

The requirements for greater reliability in enterprise and increasing demand of consumers for always-on connectivity (IoT & cloud) boosts the demand for higher bandwidth at lower cost.

Profitability of Telecom research and development, and integrators companies depends on their technical innovation, time to market and cost with a guarantee of reliability.

What makes our customers integrated solutions both performant and competitive: MicroTCA original usage for telecommunication and VadaTech constant investment in integrating the highest-end and latest silicon solutions on open-standards.

MicroTCA systems are both physically smaller and less expensive than ATCA (Advanced Telecom Computing Architecture) systems, although their internal architectures are largely similar. MicroTCA was originally intended to reduce the size of telecom systems at the edge of the network but has moved successfully into multiple telecom and non-telecom applications.

Benefits of integrating with VadaTech products?

- Redundancy (switching, power, cooling, management)
- Remote system management (temperature monitoring, intelligent cooling, hotswap, alarm)
- Clocking functions and synchronization between remote systems
- Mixed RF and network interface in single chassis
- Powerful data processing capability on latest FPGA, processors or DSP
- Higher bandwidth from board to board (PinoutPlus™, backplane slot to slot inter-connections)
- Strong base of existing IPs from VadaTech and silicon suppliers
- Small footprint integration with right power and size in rackable 19" chassis
- Pay only for what is needed with the right product ordering options
- Leveraging Modular Open System Approach (MOSA); multiple sourcing
- Capability to move to production with highly specialized product (in-house design, manufacturing and testing in USA, AS9100, IPC-class3)

Software support

VadaTech Switch Management (VTSM) software includes a stack of network layer 2 & 3 protocols and management interfaces. VTSM is designed flexible enough to be operate on VadaTech different platforms.

In addition of management interface via Command Line Interface, Web and SNMP, the VTSM stack provide the following features:

Scorpionware management GUI & IPMB bus analyzer

VadaTech's Scorpionware software can be used to access information about the current state of the deployed system "shelf" or the "carrier", obtain information such as the modules "FRU" population, or monitor alarms, power management, current sensor values, and the overall health of the shelf. The software GUI is very powerful, providing a virtual carrier and FRU construct for a simple, effective interface during deployment, management and maintenance activity.

The ViewTrace packet analyzer is a diagnostic tool for examining and generating IPMB traffic. Depending on the server configuration, ViewTrace can access bussed or radial IPMB-A/B and IPMB-L. It can parse messages defined by the IPMI, ATCA, AMC, MicroTCA and HPM standards.

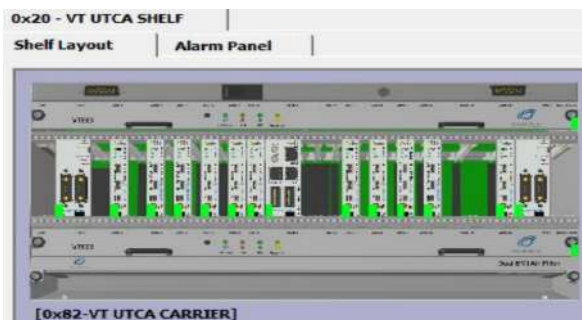

VHDL/BSP

VadaTech provides a reference design implementation for our FPGAs complete with VHDL source code, documentation and configuration binaries. The reference design focuses on the I/O ring of the FPGA to demonstrate low-level operation of the interconnections between the FPGA and other circuits on the board and/or backplane.

For ADC/DAC product line, the DAQ Series™ software provides ability to easily implement system modelling and automatic code generation from Simulink® and MATLAB® (TheMathworks, Inc.) into Vivado FPGA project via System Generator® (Xilinx).

VadaTech stack L2/L3

Layer2

- Cut-through
- Jumbo frames
- Storm control
- Priority PAUSE
- Port mirroring
- Backward Congestion Notification
- VLAN
- Port default VLAN ID
- SVL and IVL
- QinQ
- Access Control List
- QoS/CoS
- Link Aggregation
- IGMP Snooping
- (R)STP/Per VLAN (R)STP
- GVRP
- Stacking

Layer3

- RIP
- RIPng
- OSPF
- IGMP v1/2/3
- Ipv6
- PIM-SM
- DVMRP
- IGMP proxy
- DHCP Server
- DHCP Relay Agent
- Diffserv

- Small footprint 19" 1U rackmount chassis, front to rear cooling
- Mixed high-speed RF and high-bandwidth network interface in single chassis
- Powerful data processing capability on FPGA, processors or DSP and very high-bandwidth between boards with higher number of direct slot-to-slot connections

5G solutions high-bandwidth demand

High-bandwidth dual-slots switch platform: 200+Gbps with direct slot to slot connections:

With direct connection over the backplane the VT855 (or VT856) chassis provides 2+18 lanes from slot to slot. Single or mixed fabric can be used including PCIe, XAUI, SRIO, Aurora, CPRI, etc.



VT855 with VadaTech standard overlay

Some typical architectures providing high-bandwidth and based on 1U chassis are shown here after:

Optical Network Unit (ONU / ONT)

Using FPGA for packet processing and dual/quad QSFP+ on FMC VITA-57 for network interface.

The backplane and connectors are rated and tested over 12.5 Gbps per lane with 18 ports directly connected between the two slots.

Compatible with Xilinx™ CPRI IP core with Line Rate up to 12165.12 Mbps on Xilinx™ XCKU115 speed -2/-3

(contact VadaTech Sales for ordering option selection).



From top to bottom: VT951 PCIe Gen3 Rugged 1U chassis for tactical applications; VT843 PCIe Gen3 1U chassis for commercial applications; AMC240 Dual KR/KR4 to QSFP+

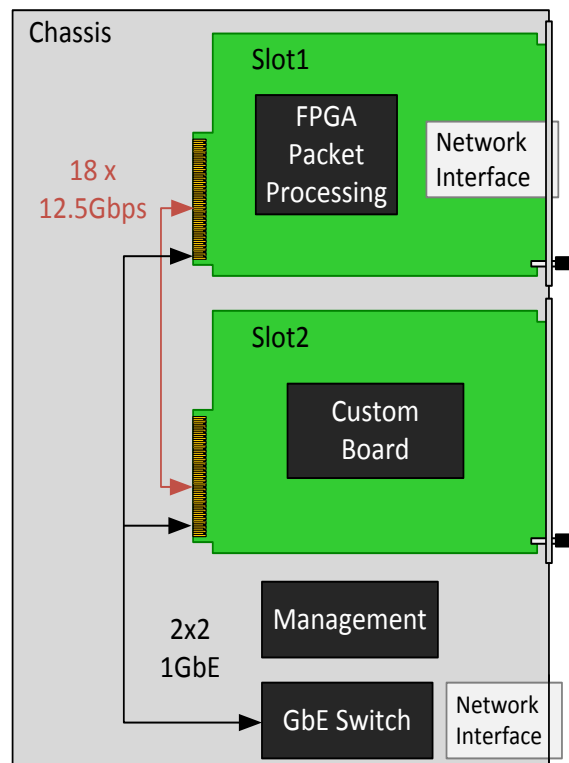

The VT855 can be ordered with one double-width slot to allow usage of AMC593 dual FMC carrier.

The AMC593 loaded with two FMC108 provides 4x 40GbE network interface and 18 ports from the Xilinx Kintex UltraScale™ FPGA to the second slot. The diagram of the AMC593 with two FMC108 is shown below.

Each FMC108 provides a dual QSFP+ for expansion to network via 10GbE, 40GbE, SRIO, PCIe, Infiniband, Aurora, etc.

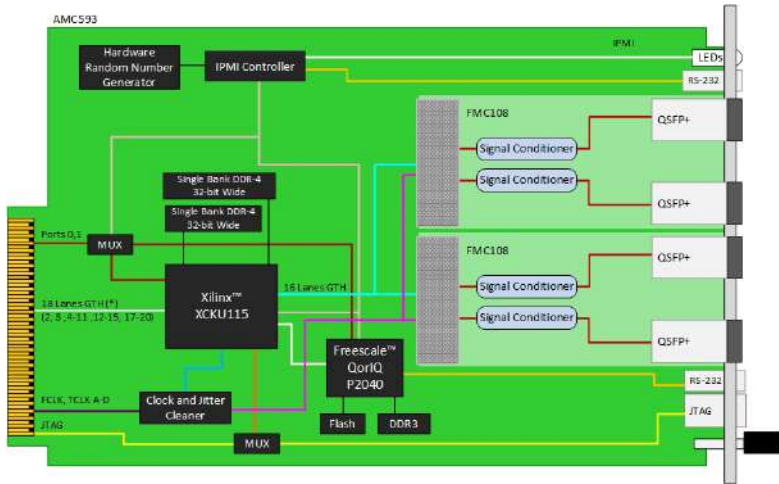

AMC593 UltraScale™ Dual FMC carrier

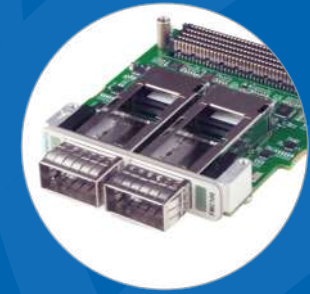

FMC108 Dual 40GbE

Clocking, SyncE and IEEE1588 PTP

SyncE compatible Network Elements such as AMC005 and AMC004 are able to receive the SyncE clock, regenerate it with local PLL and redistribute to local NE and network. AMC005 and UTC004 can also generate the Master Clock.

The IEEE1588 time stamping function inserts timing packets into the data packet stream at the master clock. The stratum traceable clock at the master ensures accurate frequency and phase time stamping. The combined packet stream is sent across to the slave without any adjustments made to the time stamp information by intermediate asynchronous nodes.

Timing packets are extracted and processed at the slave and used to generate a clock that is synchronous with the master clock's phase and frequency. AMC005 and UTC004 are IEEE1588 compatible and can also generate the Master Clock. VadaTech CPU such as AMC725, AMC726 or AMC754 are compatible with Linux PTP and can extract the clock at hardware level. Multiple platform can thus be synchronized using AMC005 or UTC004 as Master Clock and Slave Clock.

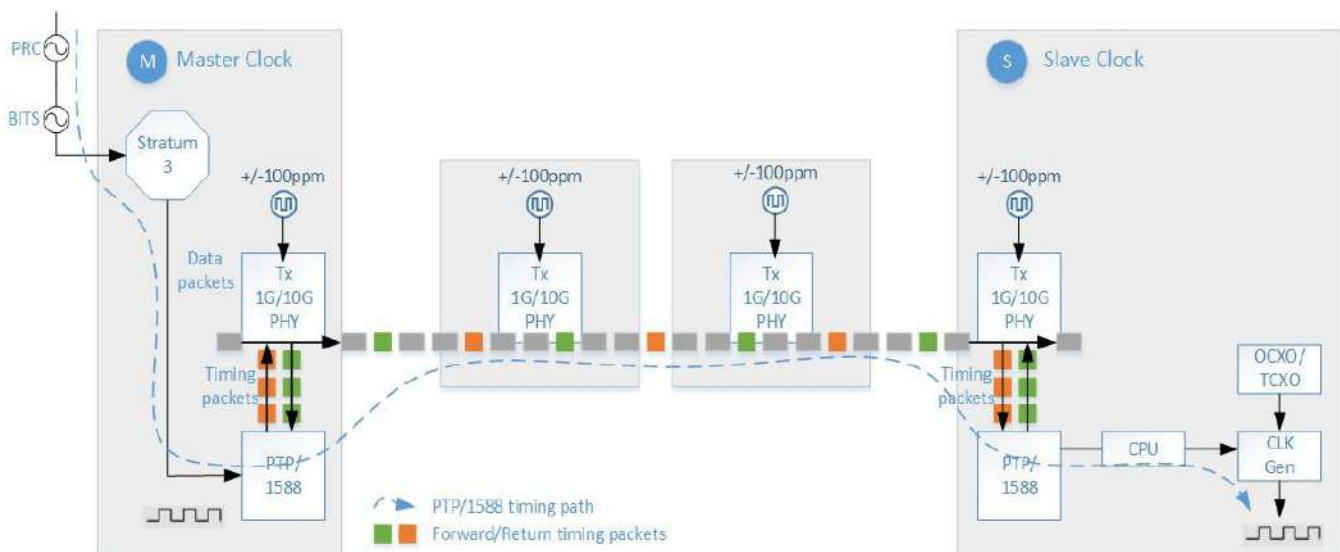

High-speed fiber testing application using very high-speed ADC and FPGA for data processing.

The AMC590 56 Gbps ADC and its Xilinx Virtex UltraScale™ provides 8 ports directly connected to the second slot via the 12.5 Gbps high-speed lanes available from the VT855 or VT856 backplane.

Compatible with Xilinx™ LogiCore IP for Aurora 64B/66B (contact VadaTech Sales for ordering option selection).

Very high-speed aggregation and transmission platform

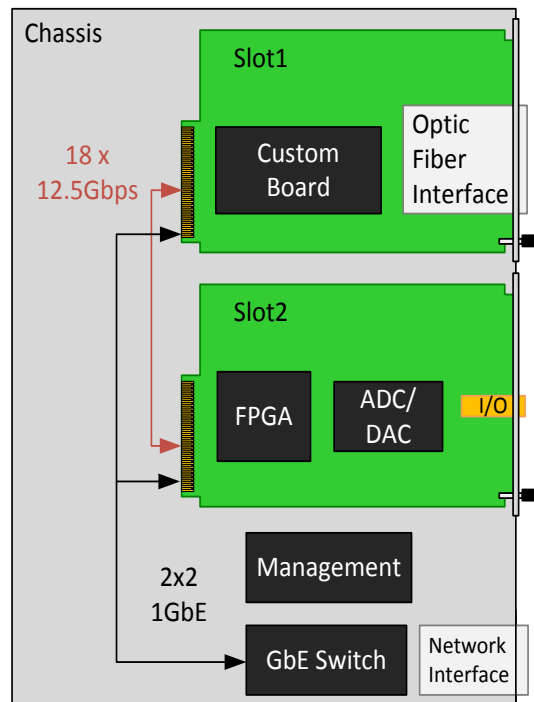

AMC590 56GSPS ADC



AMC591 dual 56GSPS ADC

High-speed, high-resolution aggregation and transmission platform:

80GbE, dual 6.4Gbps 12 bits ADC, 12Gbps 16 bits DAC and Xilinx Kintex UltraScale™ FPGA

VadaTech portfolio of high speed ADC/DAC and MIMO offers capability to generate and digitize high bandwidth waveforms. The right combination of chassis, ADC, network interface and MCH below provides an example of high-bandwidth signal generator and processor for Telecom application. Usage of FPGA allows to generate and test different modulation formats, each optimized for a different 5G communication scenario.



VT898 chassis
single MCH 6 slots



AMC599 dual 6.4GSPS ADC
dual 12GSPS DAC

Optical Line Terminal (OLT) platform

High Speed DAQ application using dual 6.4 Gbps 12 bits ADC and dual 12 Gbps 16 bits DAC with FPGA for data processing in VT898 6U chassis (picture beside).

The AMC599 Xilinx Kintex UltraScale™ provides 8 ports connected to the AMC240 network interface dual 40GbE via QSFP+.

The AMC599 and the AMC240 are connected via UTC004 with 640 Gbps switch aggregate bandwidth (in this VT898 chassis providing 80 GbE).

Additional ports 12-15 and 17-20 of the AMC599 and the backplane direct connections from slot to slot provide ability to perform data transfer using Aurora to additional FPGA or DSP boards.

100GbE telecom platform

The AMC738 with the Cavium OCTEON II CN68XX family of Multi-Core MIPS64 Processors targets Enterprise & Data Center as well as Service Provider Infrastructure for service-rich applications in secure datacenter, mobile internet and storage application hardware acceleration.

Enterprise applications include routing functions, switches, WLAN controllers, unified threat management (UTM) appliances, Ethernet services probes and other WAN optimization appliances.

Secured Cloud Services include Application Delivery Switches, Secure Storage switches, FC to IP bridges, Load Balancers, Security Appliances and Blades

Mobile Internet such as 3G/4G/5G gateways and access points, xGSNs, Evolved Packet Core (ePC)

The CN68XX processors offer high-performance, high-throughput and programmability for the L2 to L7 processing requirements of intelligent networks.

Cavium SDK includes:

- Up to 32-way SMP LINUX support
- Cavium Simple Executive for data plane applications
- Complete GNU tool-chain, GCC, GDB and DDD
- Viewzilla, Perfzilla, and Oprofile for performance tuning
- Optimized C libraries for security, regular expression, de/compression processing offload
- Support for run-to-completion or pipelined software models

- Small footprint 19" 1U rackmount chassis, front to rear cooling
- 100GbE network interface
- Strong base of existing IPs from VadaTech and silicon suppliers (SDK)
- Powerful data processing capability on FPGA and processors
- Remote system management



AMC738 in VT855 with custom overlay

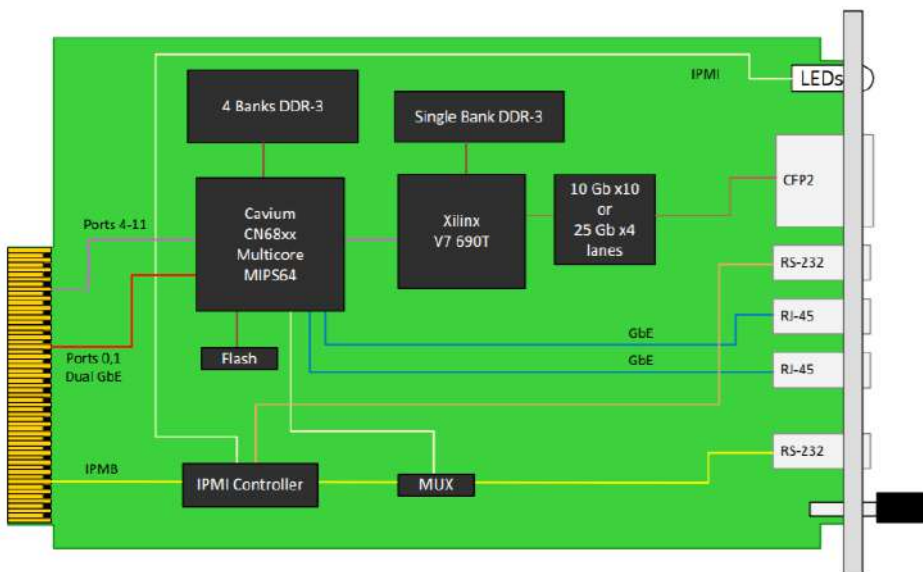

AMC738 Block Diagram



AMC534 100G



AMC738 100G

- 5G flexible Software Define Radio Prototyping
- Fronthaul or backhaul
- AMC597 unique quad AD9371
- Smart repeater application
- Frequency scanner application
- 4G Test equipment
- FDD and TDD operation
- Open standard architecture
- Integration with other VadaTech products for complete BTS infrastructure

3G / LTE

VadaTech products based on AD9361 and AD9371 enabling high-capability small-cell platforms; FMC214 and AMC597

The AD9361 is suited but not limited to single-carrier small cells that have low output power (~125 mW output). The AD9371 with its wide band and observation path is suited but not limited to support common radio platform radio solution needs to service both single-carrier and multi-carrier as well as low power all the way up to higher output powers.

The FMC214 includes AD9361 compatible with VadaTech DAQ Series™ on Zynq-7 FPGA carrier AMC518.

The AMC597 includes four AD9371 with Xilinx Kintex UltraScale™ on a single-width AMC.



FMC214
MIMO AD9361



AMC518
Zynq FPGA carrier



AMC597
Quad AD9371 with
Kintex UltraScale™

Small Cell architecture

Small Cell application using QorIQ for packet processing functions.

With 10GbE front SFP+, the AMC702 with T4240 and AMC714 with P5020 provide 8 ports directly connected to the second slot via the 12.5Gbps high-speed lanes available from the VT855 or VT856 backplane.

The second slot can be populated with a standard FPGA AMC with wideband RF transceivers such as AMC597 or AMC518 with FMC214.



AMC702
QorIQ T4240 SRIO



AMC719
QorIQ P4080 SRIO
SRIO

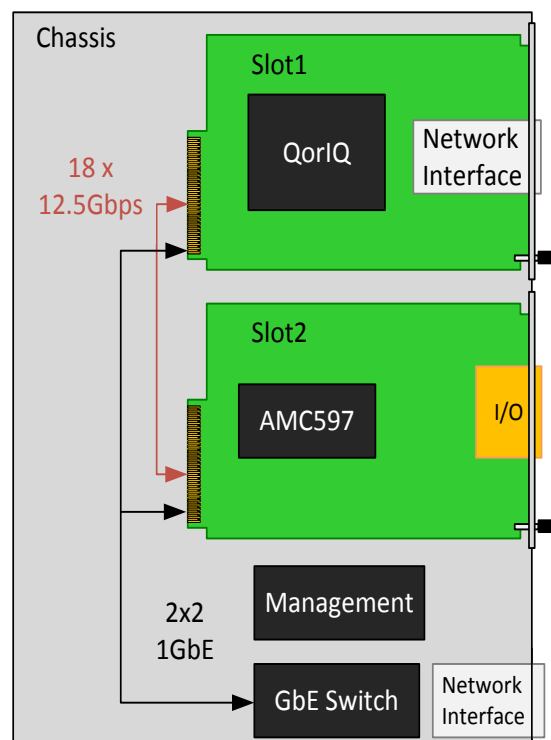

Evolution, maintenance and replacement of ATCA systems

VadaTech provides solutions based on AMC carrier to maintain/replace existing deployed platform with ATCA AMC carriers.

Time Division Multiplexing (TDM) for Mobile Switching Center (MSC)

ATC134 with rear module ART133 provides four AMC slots with dual 10GbE per AMC with managed L2 switch. The ART133 quad 10GbE allows interface with external network via SFP+ and ATCA blade management for ATCA blade processor.

The carrier can host any standard AMC including STM1-STM4 functions AMC modules.



ATC134



ART133

GbE redundancy for LTE Gateway

ATC806 is an ATCA Dual-AMC slots carrier which provides an option for GbE Switch redundancy, when used with a second ATC806.

Ordering option for GbE redundancy routing configuration: when the GbE switch on primary ATC806 fails then a redundant GbE link is established to the GbE switch of the secondary ATC806.

This architecture is compatible with Intel® I7 Processor AMC727 10/40GbE and Intel® Xeon™ E3 AMC721.

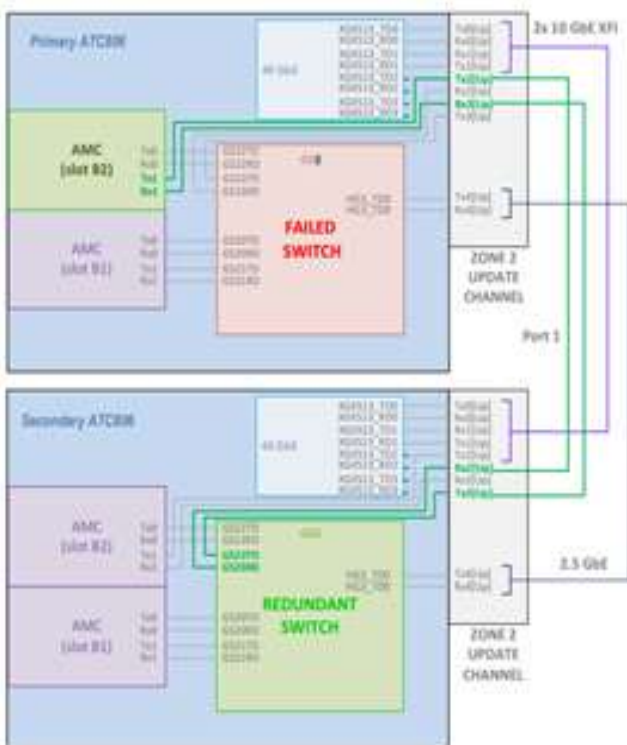

ATC806 GbE redundancy

- High packing density and Reliability, Availability, Serviceability
- Complete and flexible switch management
- Carrier for AMC network interface, storage, processors, FPGA, video and I/O
- Long term support (growing Military market ATCA-based application)



AMC727 i7 Haswell 10/40GbE



ATC806 with AMC721 and AMC624 installed

Contact

VadaTech Corporate Office

198 N. Gibson Road
Henderson, NV 89014
+1 702 896-3337

Asia Pacific Sales Office

7 Floor, No. 2, Wenhua Street
Neihu District, Taipei
114, Taiwan
+886-2-2627-7655

VadaTech European Sales Office

VadaTech House, Bulls Copse Road
Totton, Southampton
SO40 9LR United Kingdom
+44 2380 016403

info@vadatech.com | www.vadatech.com

Choose VadaTech

We are technology leaders

- First-to-market silicon
- Continuous innovation
- Open systems expertise

We commit to our customers

- Partnerships power innovation
- Collaborative approach
- Mutual success

We deliver complexity

- End-to-end Processing
- System management
- Configurable solutions

We manufacture in-house

- Agile production
- Accelerated deployment
- AS9100 accredited



vadatech
THE POWER OF VISION

XILINX.
ALLIANCE PROGRAM
CERTIFIED