

FEATURES

- Open VPX VITA 62 compliant
- 3U VPX, 1.0" pitch single slot
- Wide input range: 100-125VAC (L-N)
- Input transient protection
- One high power DC Output: +28V/30A
- Auxiliary DC Outputs: +3.3V Aux/0.4A
- Low noise & ripple
- Input-output isolation
- Excellent load regulation
- Overcurrent, Overvoltage, Over temperature protection
- Efficiency of 90% typical
- High power density
- Conduction cooled at card edge
- Conformal coating on PCB
- Designed to meet MIL-STD-461F
- ENABLE*, INHIBIT* controls per VITA 62
- Output voltage FAIL* signal
- LED indication



OVERVIEW

The Behlman VPXtra™800A series COTS DC to DC power supply is a rugged, highly reliable, conduction cooled, switch mode unit built for high-end industrial and military applications. The VPXtra™800A is VITA 62, Open VPX compliant, 3U, power supply that delivers up to 1150 Watts of DC power via two outputs. The VPXtra™800A accepts 115/200VAC, 3-phase input, IAW MIL-STD-704, and can supply a high power DC output at various power levels dependent on cooling capability. When used in conjunction with Behlman HU700HV minimum hold-up time of 50msec at 800W of output power can be achieved.

The VPXtra™800A power supply has no minimum load requirement and has overvoltage and short circuit protection as well as over current and thermal protection. The power supply is designed to support the rigors of mission critical airborne, shipboard, vehicle and mobile applications.

Designed and manufactured with Xtra-Cooling™ technology, Xtra-Reliable™ design and Xtra-Rugged™ construction makes the Behlman VPXtra™800A your best choice.

Absolute Maximum Ratings:

(Stresses above those listed below may cause permanent damage to the unit)

Parameter	Notes	Min	Max	Units
Input Voltage (continuous operation)	Line to Neutral (L-N), Three-phase power	100	125	VAC
Input Current	@71C Card Edge, 1150W Output Power		4	A
	@85C Card Edge, 800W Output Power		3.1	A
Input Frequency		360	800	Hz
Operating Temperature	Measured at Card Edge	-40	85	°C
Maximum Output Power	Card Edge @ 85C		800	W
	Card Edge @ 71C		1150	W
Storage Temperature		-55	105	°C
Isolation Voltage	Input to Output		1000	V
Isolation Voltage	Input to Case		1000	V
Isolation Voltage	Output to Case		500	V
Isolation Resistance	Input to Case	10		MΩ

Input Characteristics:

Parameter	Notes	Min	Typical	Max	Units
Operating Input Voltage Range	Line to neutral	100	115	125	VAC
Turn-On Threshold	Line to neutral		75		VAC
Turn-Off Threshold	Line to neutral		72		VAC
Input Standby Current	115VAC Input, Enable De-asserted (Input Off), Inhibit Asserted (Output Off)		42mA		mA
Input Standby Current	115VAC Input, Enable Asserted (Input On), Inhibit Asserted (Output Off)		43mA		mA
Input No Load Current	115VAC Input, Enable Asserted (Input On) and Inhibit De-asserted (Output On)		64mA		mA
Power Factor	Output Power of 800W, Frequency 400Hz		0.93		
Inrush Current			8	14	Apk

Output Characteristics, +28V Output:

Parameter	Notes	Min	Typical	Max	Units
Output Voltage Set Point		24.00	28.00	33.00	V
Line Regulation	100-125VAC (L-N) input range, 100% Output Load		0.05	0.25	%
Load Regulation	10-100% Load		3.4	4	%
	0-100% Load		6.25	7	%
Output Ripple/Noise Peak to Peak	See Note 3		40	120	mVp-p
Output Ripple/Noise RMS	See Note 3			50	mV _{rms}
Maximum Capacitive Load				2,000	uF
Output Current Range		0		30	A
Output Overvoltage Protection	From 25-100% Output Load	35.0			V
	From 0-25% Output Load	36.4			
Output Overcurrent Protection		45	60	72	A
Transient Response	See Figure				

Output Characteristics, +3.3V Aux

Parameter	Notes	Min	Typical	Max	Units
Output Voltage Set Point		3.25	3.3	3.35	V
Line Regulation	100-125VAC (L-N) input range, 100% Output Load		0.1	0.3	%
Load Regulation	From 0-100% Load		2.1	3.0	%
Output Ripple/Noise Peak to Peak	See Note 3		22	50	mVp-p
Output Ripple/Noise RMS	See Note 3			20	mV _{rms}
Output Current Range		0		0.4	A
Output Overcurrent Protection		0.45	0.5	0.6	A

General Characteristics:

Parameter	Notes	Min	Typical	Max	Units
Power			800	842	W
Efficiency 100% Load	+28V@28.5A, +3.3V Aux@ 0.4A, 115VAC Input (L-N) See Figure 9		90		%
Turn-On Delay, 3.3V output	From application of input power (ENABLE* is asserted). See Figure 3		400		ms
Turn-On Delay, +12V output	From INHIBIT* de-assertion. See Figure 4		350		ms

Controls and Signals (per VITA 62):

Name	Function	Description
ENABLE* (Input)	Input power control	Active Low, referenced to SIG RTN. When asserted, internal input power bus is enabled
INHIBIT* (Input)	Output power control for +28V outputs	Active Low, referenced to SIG RTN. When asserted, +28V output is disabled.
FAIL* (Output)	Reports out of tolerance output voltages	Open Drain Output (3.3V, 20mA) external pull up required. Logic low indicates output voltage(s) out of tolerance.

Output Power Status vs. Input Power and Control Signals:

Input Power	ENABLE*	INHIBIT*	+28V output	+3.3V Aux output
Not present	X	X	OFF	OFF
Present	Not asserted (high)	X	OFF	OFF
Present	Asserted (low)	Asserted (low)	OFF	ON
Present	Asserted (low)	Not asserted (high)	ON	ON

Indicators:

Indicator	Description
DC Status, Bi-Color LED (Red and Green)	Red LED indicates outputs off or out of range; Green LED indicates outputs on.

Note 1: Maximum continuous output current is limited to 40A by the connector pin rating; for extended operation, de-rate output power accordingly.

Note 2: All measurements are performed at Nominal Input (28VDC) and at ambient temperature of 25° C, unless otherwise specified.

Note 3: Ripple and noise measured at output connector, across parallel connection of 10uF tantalum and 0.1uF ceramic capacitors, 20MHz Bandwidth.

Note 4: Unless otherwise specified, all measurements made at input frequency of 400Hz.

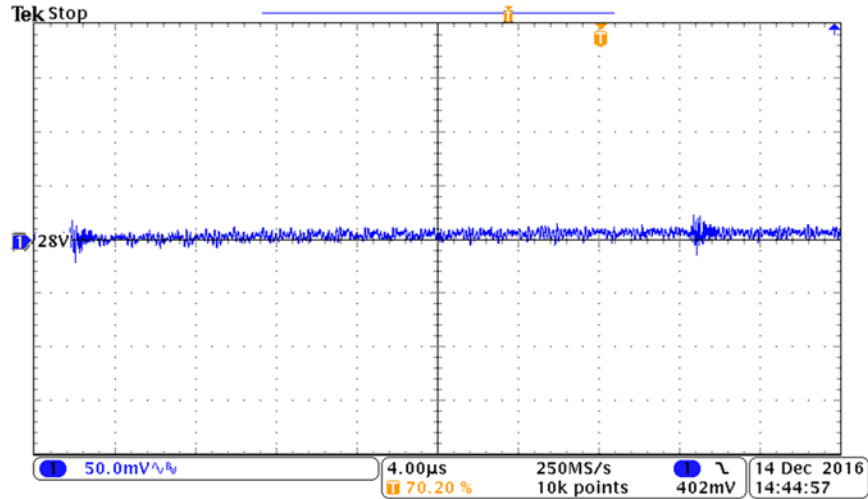

Figure 1: 28V Output Ripple

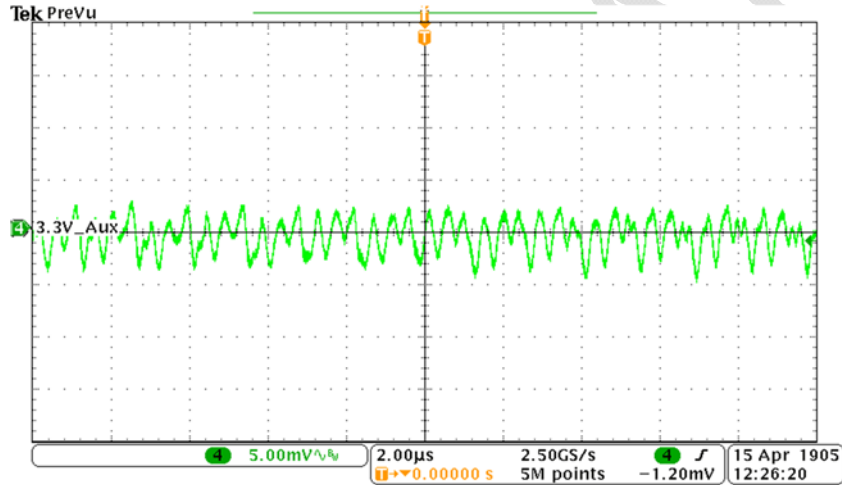

Figure 2: 3.3V Output Ripple

Output voltages start up sequence:

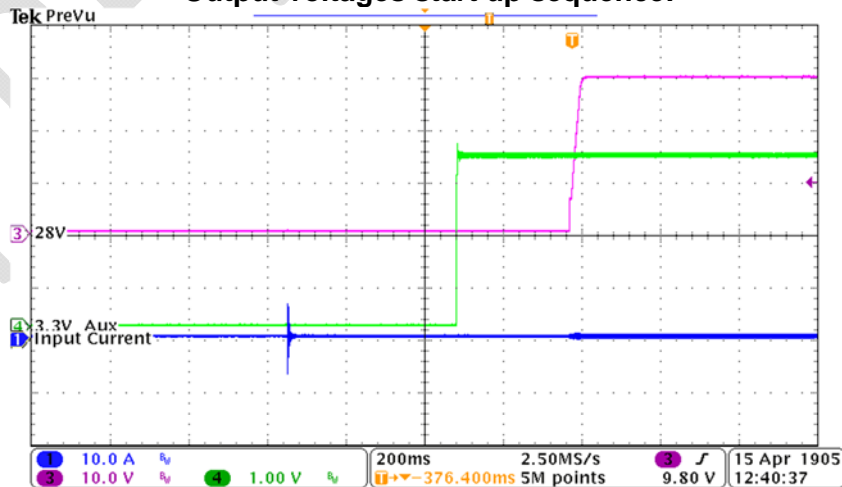

Figure 3: Turn-on delay from application of power, ENABLE* asserted, INHIBIT* de-asserted

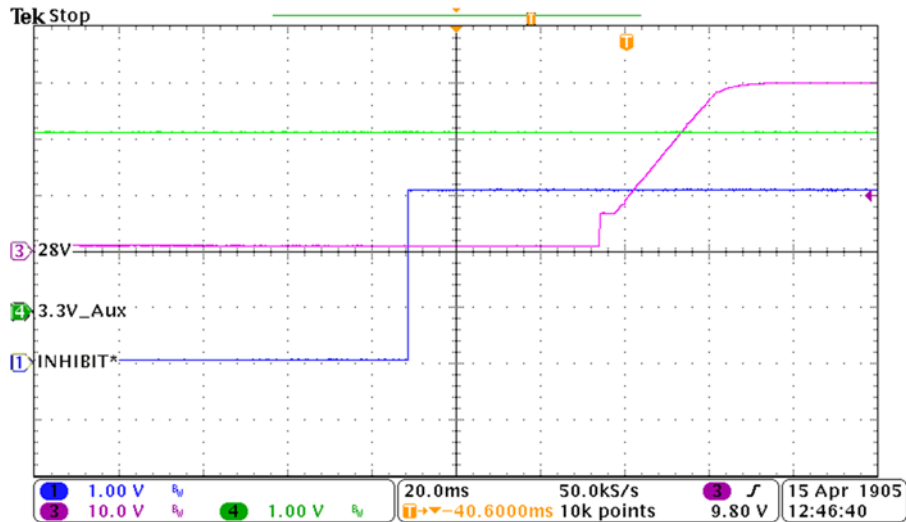

Figure 1: Turn-on delay from INHIBIT* de-assertion, main outputs

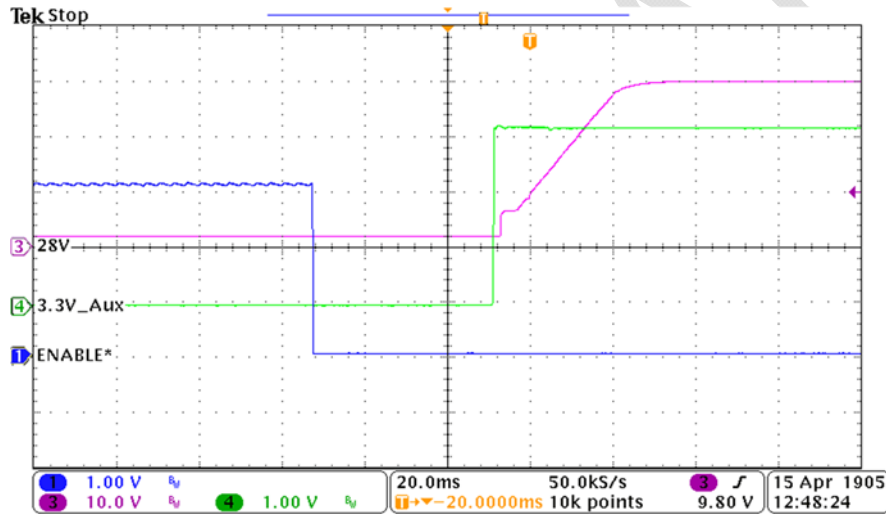

Figure 5: Turn-on sequence 28V, ENABLE* asserted, INHIBIT* de-asserted

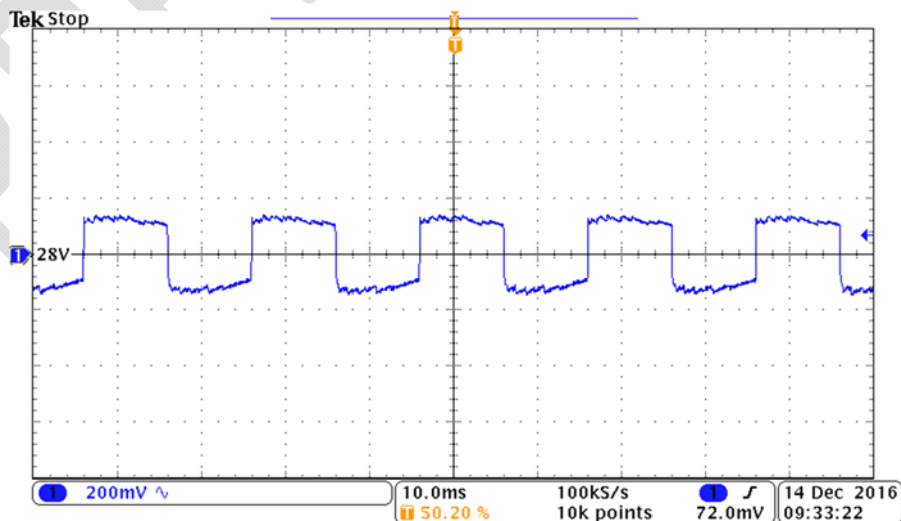

Figure 6: +28V output transient response, 50%-75% load change

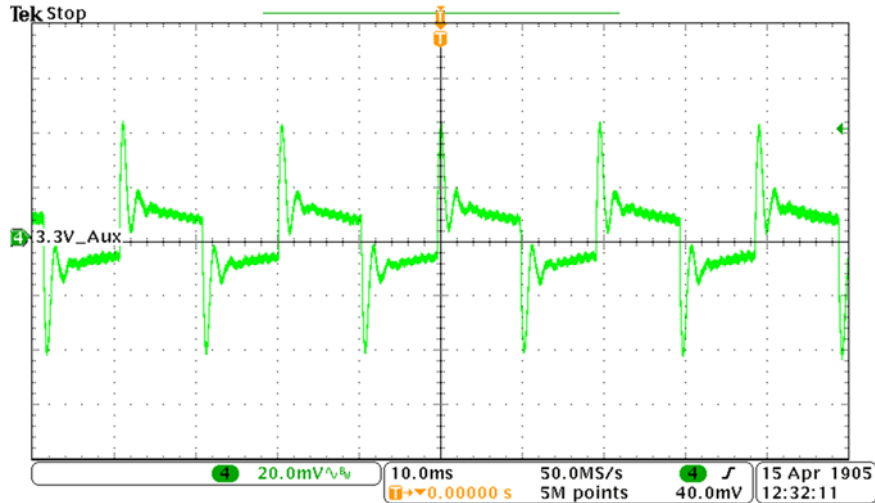

Figure 7: +3.3V output transient response, 50%-75% load change

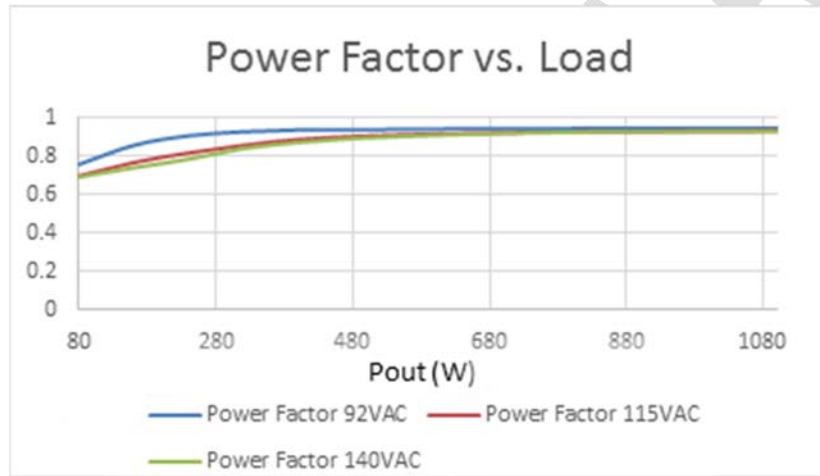

Figure 8: Power Factor vs. Load for Minimum, Nominal and Maximum input voltage

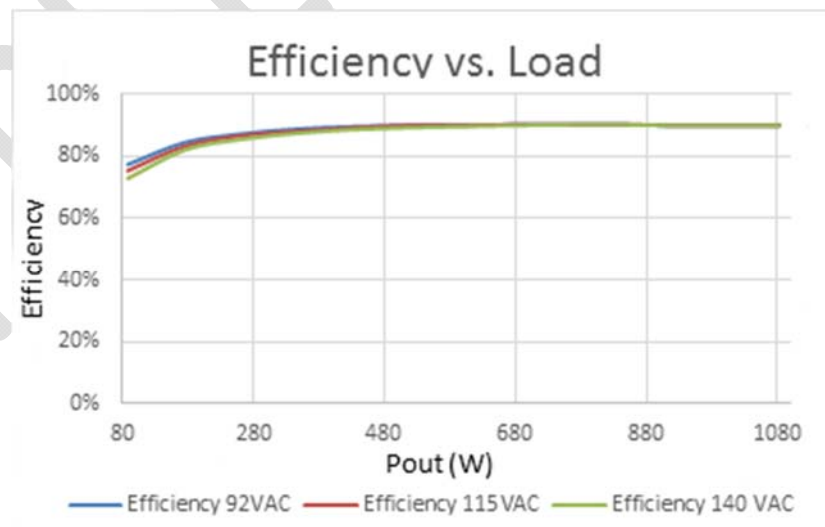

Figure 9: Efficiency vs. Load for Minimum, Nominal and Maximum input voltage

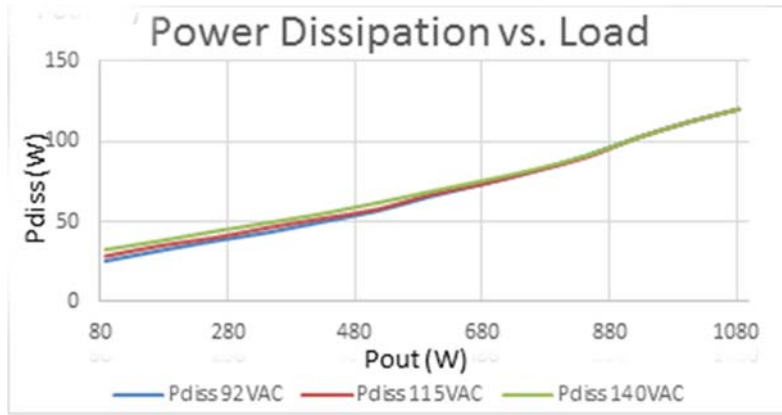

Figure 10: Power dissipation vs. Load for Minimum, Nominal and Maximum input voltage

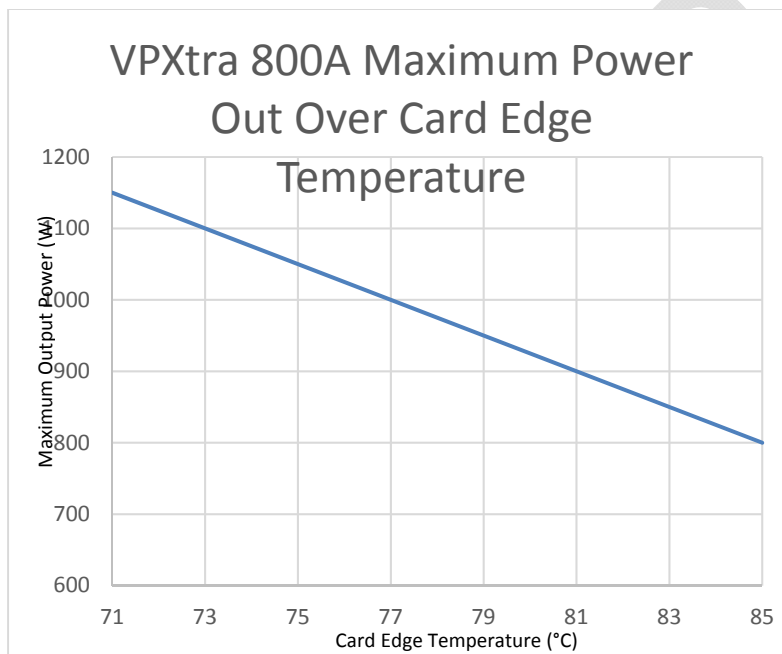

Figure 11: Maximum Output Power over Card Edge Temperature

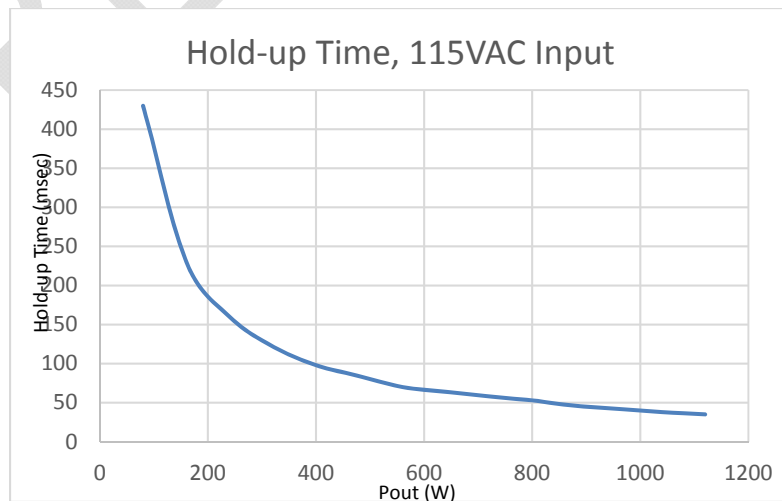

Figure 11: Hold-up Time at 115VAC Input with VPXtra HU700HV

Connector Pin Out and Descriptions VPXtra800A:
P0

CONNECTOR, POWER/SIGNAL
 MANUFACTURER: T.E. CONNECTIVITY (TYCO).
 MANUFACTURER P/N: 1-6450839-4
 MATING CONNECTOR P/N: 2-6450869-7

3U P0 CONNECTOR PIN OUT

PIN NUMBER	RATED CURRENT (A)	PIN NAME	FUNCTION	COMMENTS
LP1	20A	PHASE A	PHASE A	} 3Ø 115V/400Hz I.A.W. MIL-STD-704
LP3	20A	PHASE B	PHASE B	
LP5	20A	PHASE C	PHASE C	
LP7	20A	NEUTRAL	N/U	
LP9	20A	CHASSIS	CHASSIS	BONDED TO COVERS
LP11	20A	HOLD UP+	HOLD UP+	270V FOR HU700HV
LP13	20A	HOLD UP-	HOLD UP-	270V RTN FOR HU700HV
A1	<1A	GA0*	N/U	
A2	<1A	GA1*	N/U	
A3	<1A	SYS_RESET*	N/U	
B1	<1A	SM0	N/U	
B2	<1A	SM1	N/U	
B3	<1A	UD0	N/U	
C1	<1A	UD1	N/U	
C2	<1A	INHIBIT*	INHIBIT*	CONNECT TO SIGNAL_RTN TO DISABLE THE 28V OUTPUT
C3	<1A	FAIL*	FAIL*	OPEN-DRAIN (EXTERNAL PULL-UP REQUIRED) HIGH OUTPUT O.K., LOW: FAULT
D1	<1A	SIGNAL_RETURN	SIGNAL_RETURN	RETURN FOR ALL CTRL SIGNALS AND +3.3V AUX
D2	<1A	ENABLE*	ENABLE*	CONNECT TO SIGNAL RTN TO ENABLE INPUT POWER
D3	<1A	3.3V_AUX	3.3V_AUX/.4A	ISOLATED FROM 28V, RETURNS THROUGH SIG_RTN
P1	40A	28V OUT	28V OUT/30A	
P2	40A	28V OUT RTN	28V OUT RTN	

PART NUMBER	ROWS	POWER												SIGNAL			POWER		
		LP1	LP2	LP3	LP4	LP5	LP6	LP7	LP8	LP9	LP10	LP11	LP12	LP13	1	2	3	P1	P2
1-6450839-4	D C B A	LM	-	LM	-	LM	-	LM	-	LM	-	LM	-	LM	J	J	J	TM	TM
															K	K	K		
															N	N	N		
13LP+12S+2P														S	S	S			

CONNECTOR FACE VIEW DETAIL

Mechanical Dimensions VPXtra800A:

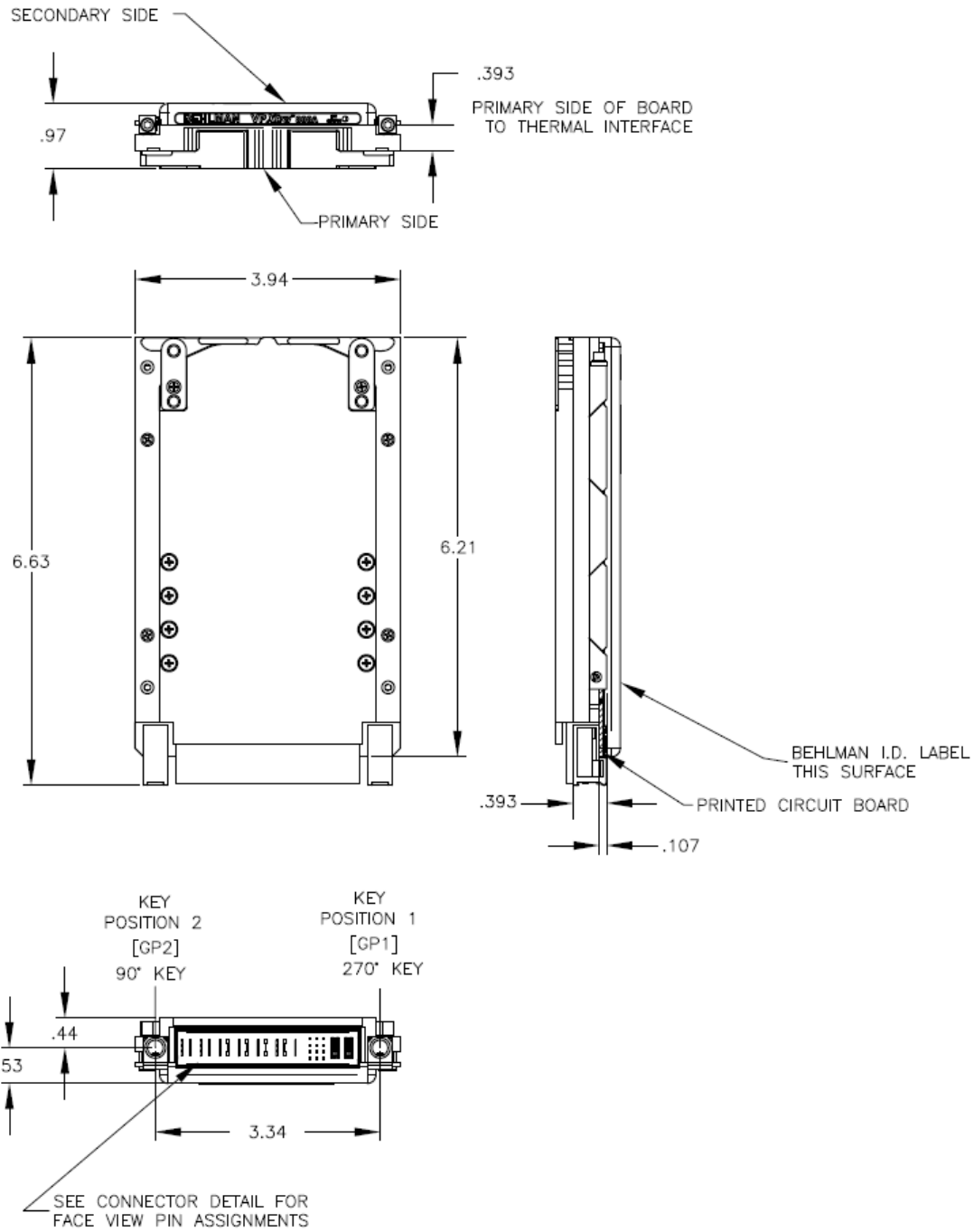

Connector Pin Out and Descriptions VPXtra HU700HV:
P0

CONNECTOR, POWER/SIGNAL
 MANUFACTURER: T.E. CONNECTIVITY (TYCO).
 MANUFACTURES P/N: 6450839-7

3U P0 CONNECTOR PIN OUT

PIN NUMBER	RATED CURRENT (A)	PIN NAME	FUNCTION	NOTES AND COMMENTS
P1	40A	+270V	+270V	DC INPUT AS WELL AS HOLDUP OUTPUT
P2	40A	+270V RTN	+270V RTN	DC INPUT RETURN AS WELL AS HOLDUP OUTPUT RETURN
LP1	20A	CHASSIS	CHASSIS	BONDED TO COVERS
A1	<1A	UD1	N/U	
B1	<1A	UD2	N/U	
C1	<1A	UD3	N/U	
D1	<1A	UD4	N/U	
A2	<1A	VBAT	N/U	
B2	<1A	FAIL*	N/U	
C2	<1A	INHIBIT*	N/U	
D2	<1A	ENABLE*	N/U	
A3	<1A	UDO	READY	
B3	<1.5A	+12_AUX	N/U	
C3	<1A	NED	N/U	
D3	<1A	NED_RETURN	N/U	
A4	<1.5A	3.3V_AUX	N/U	
B4	<1.5A	3.3V_AUX	N/U	
C4	<1.5A	3.3V_AUX	N/U	
D4	<1.5A	3.3V_AUX	N/U	
A5	<1A	GA0*	N/U	
B5	<1A	GA1*	N/U	
C5	<1A	SM0	N/U	
D5	<1A	SM1	N/U	
A6	<1A	SM2	N/U	
B6	<1A	SM3	N/U	
C6	<1.5A	-12V_AUX	N/U	
D6	<1A	SYSRESET*	N/U	
A7	<1A	P01_SHARE	N/U	
B7	<1A	P02_SHARE	N/U	
C7	<1A	P03_SHARE	N/U	
D7	<1A	SIGNAL_RETURN	SIGNAL RETURN	RETURN FOR READY SIGNAL
A8	<1A	P01_SENSE	N/U	
B8	<1A	P02_SENSE	N/U	
C8	<1A	P03_SENSE	N/U	
D8	<1A	SENSE_RETURN	N/U	
P3	40A	P03	N/U	
P4	40A	POWER_RETURN	N/U	
P5	40A	POWER_RETURN	N/U	
LP2	20A	P02	N/U	
P6	40A	P01	N/U	

PART NUMBER	ROWS	POWER			SIGNAL								POWER				
		P1	P2	LP1	1	2	3	4	5	6	7	8	P3	P4	P5	LP2	P6
6450839-7	D	TT	TT	LT	Z5	Z5	Z5	Z5	Z5	Z5	Z5	TT	TT	TT	LT	TT	
	C				Y5	Y5	Y5	Y5	Y5	Y5	Y5						
	B				R5	R5	R5	R5	R5	R5	R5						R5
	A				O5	O5	O5	O5	O5	O5	O5						O5
2ACP+1LP+32S+3HDP+1LP+1HDP																	

CONNECTOR FACE VIEW DETAIL

Mechanical Dimensions VPXtra HU700HV:

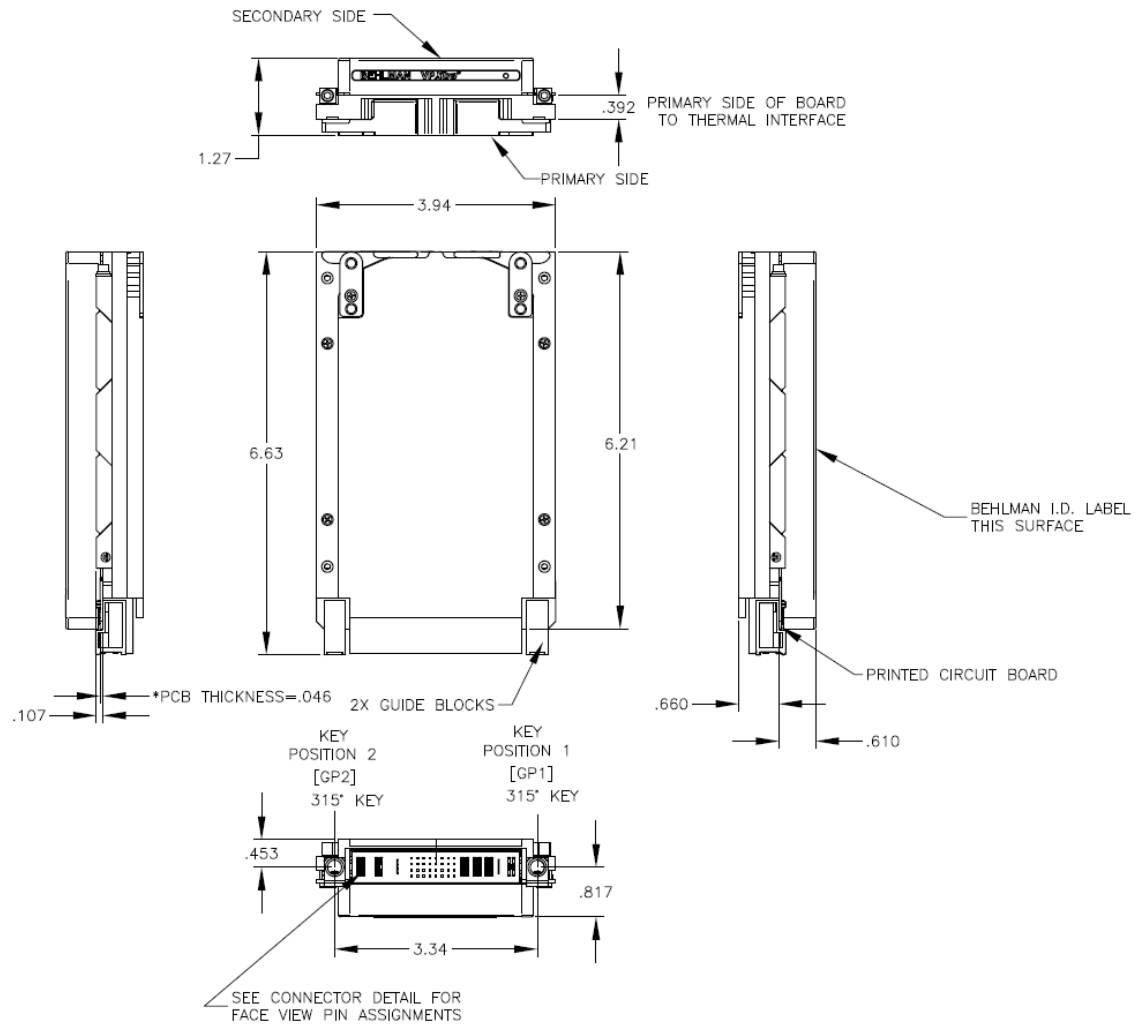

PRL